

DRAWINGS MUST BE APPROVED BEFORE WORK WILL START.
DRAWING APPROVAL VERIFIES THAT ALL DIMENSIONS ARE
CORRECT AND ACCEPTABLE FOR THE CUSTOMER.

APPROVED BY:

SIGNED:

DATE:

NOTES:

EXHAUST VOLUME AND AIR MAKE-UP VOLUME:
AS SPECIFIED BY MECHANICAL ENGINEER

ALL WELDED HOOD CONSTRUCTION TO
STANDARDS EQUAL TO N.F.P.A. #96. U.L.C.
LISTED - FILE # CR2206

20" X 20" GREASE EXTRACTORS, U.L.C. LISTED
- FILE # CR1034

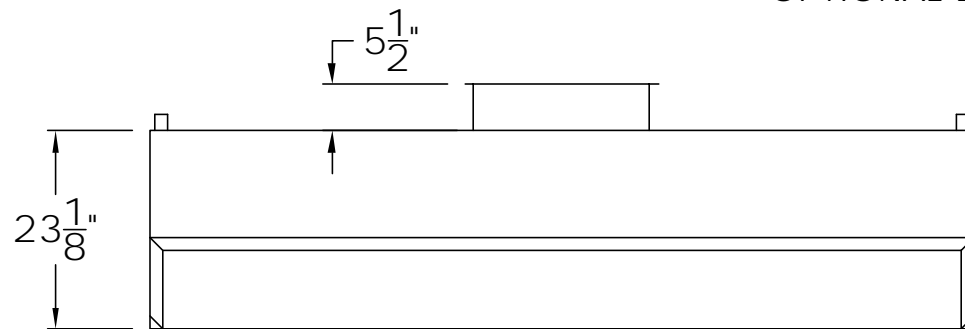

OPTIONAL LIGHTS

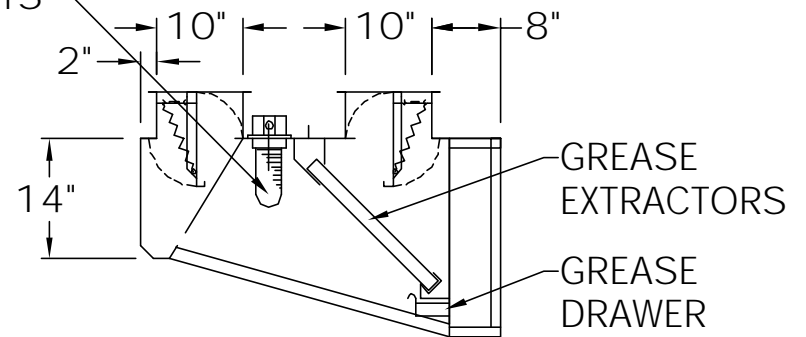

CROSS-SECTION



145 Millwick Drive, Toronto, Ontario, M9L 1Y7
Tel : 416-742-9673 Fax : 416-742-6486
e-mail : sales@herculesfoodequipment.com

PROJECT:

HERCULES
EXHAUST HOOD

SCALE: NTS

DATE:

CHECKED BY:

DRAWN BY:

REVISION DATE:

ITEM #:

THE CONTRACTOR AND ALL HIS SUB TRADES
SHALL VERIFY ALL DIMENSIONS PRIOR TO THE
COMMENCEMENT OF WORK.

THIS DRAWING IS THE PROPERTY OF HERCULES FOOD EQUIPMENT AND
IS NOT TO BE USED OR REPRODUCED IN WHOLE OR IN PART WITHOUT
THE WRITTEN CONSENT OF HERCULES FOOD EQUIPMENT